

# Flow Divider and Flow Divider/Combiner Valves



## Applications

There are two types of flow dividers and flow divider/combiners:

- Sliding spool
- Rotary (usually gear)

Each type has its own set of performance characteristics:

- Flow range
- Pressure capability
- Accuracy
- Unique application parameters

Sun offers sliding spool, pressure-compensated flow dividers and flow divider/combiners which can be used to split or combine flow in a variety of applications. These cartridges are simple devices, both in appearance and operation. The flow dividers incorporate just one moving part, while flow divider/combiners have up to three moving parts. Be aware that simplicity of design and construction does not necessarily lead to application simplicity when it comes to specifying these devices.

When using Sun spool type flow dividers and flow divider/combiners, several areas of application sensitivity must be taken into consideration.

- Flows below the designated operating range, entrapped air, and/or contamination can cause these devices to produce inaccuracies larger than the individual cartridge-specified tolerance limits.
- In all flow divider and flow divider/combiner applications, inaccuracies are cumulative. Although two or more devices in series will perform within the stated accuracy limits, the cumulative effect on accuracy must be considered as to how it will affect overall system performance.

Two of the most common application areas include multiple cylinder circuits and hydraulic motor circuits.

### Cylinder Applications

In the dividing mode, pressure-compensated flow dividers (or flow divider/combiners) split flow within the valve's accuracy limits. Inherent design characteristics will cause the path with the **highest load pressure to receive a higher percentage of the flow**. If a rigid mechanism ties the cylinders together, the lead cylinder can pull the lagging cylinder and cause it to cavitate.

In the combining mode, these devices will combine flow within the stated accuracy limits. However, the compensating characteristics will cause the leg with the **lowest load pressure to receive a higher percentage of the flow**.

***Synchronization at the end of the cylinder stroke is a must, or an additive accuracy error can be expected with each stroke. In applications where the mechanisms between the two cylinders turn out to be too rigid, operating inaccuracy will cause the eventual lock-up of the system, with potential damage to the mechanical structure.***

### Hydraulic Motor Applications

Hydraulic motor drive systems will be affected by the compensating characteristics in the same manner as cylinders. Rigid frames or mechanisms tying the motors together (mechanically synchronized motion of the motor's output shafts; e.g. wheels to the pavement, or sprockets to conveyers) will contribute to cavitation, lock-up, and pressure intensification.

Variations in speed and/or possible lock-up can also be caused by differences in motor displacement, motor leakage, differences in wheel diameter, plus variations in the coefficient of friction between the wheels and driving surface.

On multiple wheel drive vehicles, extreme pressure intensification can occur. For example, a four wheel drive vehicle going down a grade has all wheels gripping. Deceleration then induces a 3000 psi (210 bar) load on all four wheel motors. At this point, three of the four motors lose traction, causing the fourth motor to see a theoretical deceleration pressure of 12,000 psi (840 bar).

- Adding relief valves at the cylinder or motor ports will minimize the potential for pressure intensification along with its resulting system damage.
- Installing make-up (anti-cavitation) check valves at the cylinder or motor ports can help with the cavitation problem.
- Properly sized slip orifices in a tractive motor drive circuit can alleviate lock-up and allow for terrain variations or articulated steering.

The "bottom line" is: *Each flow divider and flow divider/combiner application must be thoroughly analyzed. Every consideration must be given to expected system performance under all possible operating conditions. Precautions must be taken in order to insure that none of the problems previously discussed can occur and affect the satisfactory performance of the entire system.*

## Design Concepts and Features

Sun offers seven sliding spool, pressure compensated flow dividers and flow divider/combiners, four standard accuracy higher flow versions, and three high accuracy lower flow versions. Input flows range from 0.3 gpm (1 L/min) to 80 gpm (320 L/min) with operating pressures up to 5000 psi (350 bar). **(Be aware that with all versions there will be no dividing or combining when flows are below the minimum rated input flow. If flow starts at zero, the cartridge will essentially be a tee until the minimum flow rating is reached.)** All seven versions are available in four frame sizes, with each frame size featuring a wider flow range than is typically found in other cartridge type flow dividers and flow divider/combiners. (The high accuracy versions are rated at approximately half the capacity of the standard accuracy units for a given frame size.)

**Flow Divider (Only) Cartridges – FS\*D, FSBD and FS\*C**

Sun standard accuracy FS\*D, plus high accuracy FSBD and FS\*C flow divider cartridges, are suited for applications that use hydraulic motors or cylinders where flow division control is required in only one direction. (If reversal of the actuator direction is desired, a reverse flow check valve would be required.) In addition, they can be used where multiple circuits are serviced from one pump supply. (See Figures 1 and 2) Optimized performance parameters include:

- Broad flow capacity relative to physical size.
- Standard accuracy divisional tolerances range from +/- 3.5% at maximum rated input flow down to +/- 6.5% at minimum rated input flow, with 5000 psi (350 bar) differential between legs.
- High accuracy divisional tolerances range from +/- 2.5% at maximum rated input flow down to +/- 4.5% at minimum rated input flow, with 5000 psi (350 bar) differential between legs.
- Multiple flow split options (except for FS\*C versions) – 50:50, 40:60, and 33:67. (Regardless of split ratio, port 2 [outlet] always produces lower flow than port 4 [outlet].)
- Reverse flow path is unpredictable as these flow divider (only) cartridges are not designed to combine flow from the opposite direction.

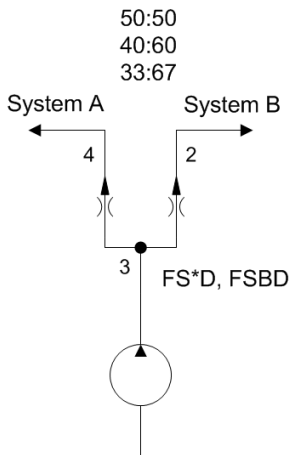

**Figure 1.**

Use flow divider (only) cartridges to provide flow to two separate systems from one supply. Secondary systems can be tailored to three proportional flow requirements (i.e. 50:50, 40:60, or 33:67).

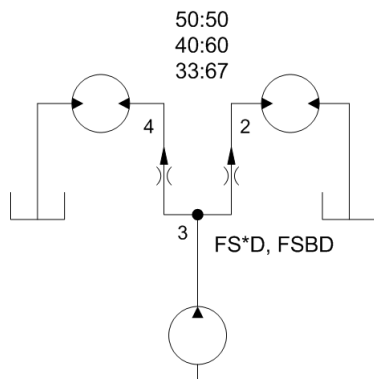

**Figure 2.**

Use flow divider (only) cartridges for two parallel hydraulic motors being driven only in one direction. Unequal speeds can be accomplished with motors of equal displacement using the 40:60 or 33:67 ratios. Motors with unequal displacement ratios that match either the 40:60 or 33:67 flow divider ratios, can be operated at the same speed, within the accuracy limits of the flow divider and the motors' volumetric efficiency.

**Closed Center Flow Divider/Combiner Cartridges – FS\*A, FSAA, FSBA and FS\*G**

Sun standard accuracy FS\*A and high accuracy FSAA, FSBA, and FS\*G closed center flow divider/combiner cartridges can be used in applications that use hydraulic motors or cylinders where bi-directional flow division control is required. (See Figures 3 and 4) Optimized performance parameters include:

- Broad flow capacity relative to physical size.
- 50:50 flow split ratio only.
- A unique closed center feature that will block flow when port 3 (inlet) is closed. Although the limited spool leakage between ports does not provide zero leak load holding capability, this feature can be helpful in minimizing cross-port flow and drift.
- Standard accuracy divisional and combining tolerances range from +/- 3.5% of 50% at maximum rated input flow down to +/- 6.5% of 50% at minimum rated input flow, with 5000 psi (350 bar) differential between legs. High accuracy divisional and combining tolerances range from +/- 2.5% of 50% at maximum rated input flow down to +/- 4.5% of 50% at minimum rated input flow, with 5000 psi (350 bar) differential between legs.

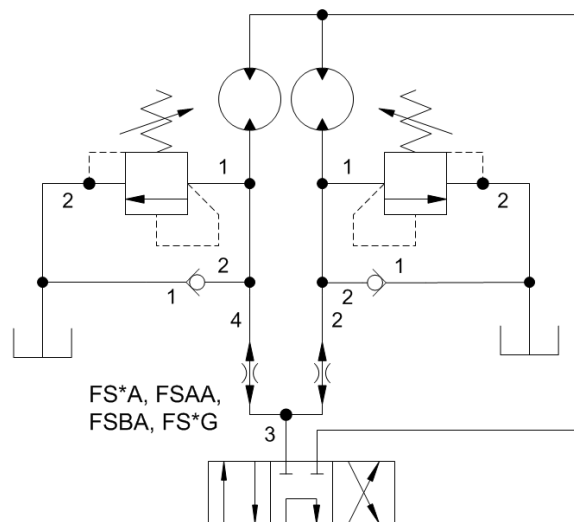

**Figure 3.**

For two hydraulic motors rotating at the same speed and in both directions, flow divider/combiner cartridges are the correct choice. However, if the application allows the motors to become mechanically linked during operation, it is recommended that relief valves, anti-cavitation check valves, or slip orifices be added to the circuit.

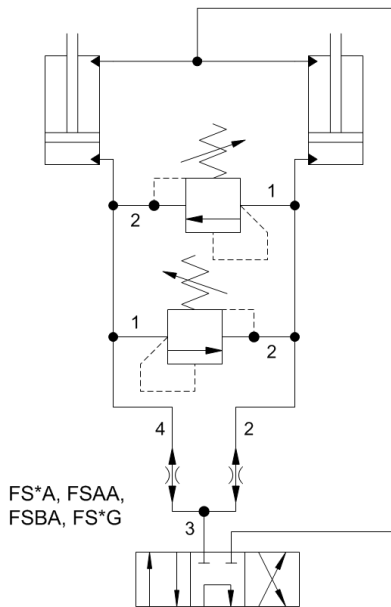

FS\*A, FSAA,  
FSBA, FS\*G

Closed center flow divider/combiner cartridges will accurately split the flow into two cylinders in both directions and will provide limited load holding capability (cross-port leakage is limited to spool clearances). Synchronization at the end of stroke can be accomplished by adding cross-port relief valves. **Cylinders must not be rigidly connected together!**

Figure 4.

**Closed Center, High Capacity, Flow Divider/Combiner Cartridges – FS\*H**

Sun high capacity FS\*H flow divider/combiner cartridges are primarily for use in tractive drive circuits. (See Figure 5) Performance parameters include:

- High flow capacity. (30% greater than equivalent frame size standard flow divider/combiners.)
- Slightly lower accuracy than standard accuracy divider/combiners. (Divisional and combining tolerances range from +/- 4% of 50% at maximum rated input flow down to +/- 6.5% of 50% at minimum rated input flow, with 5000 psi (350 bar) differential between legs.
- 50:50 flow split ratio only.
- A unique closed center feature that will block flow when port 3 (inlet) is closed.
- Differential slip for tractive drive systems must be created by adding orifices in the body/manifold.

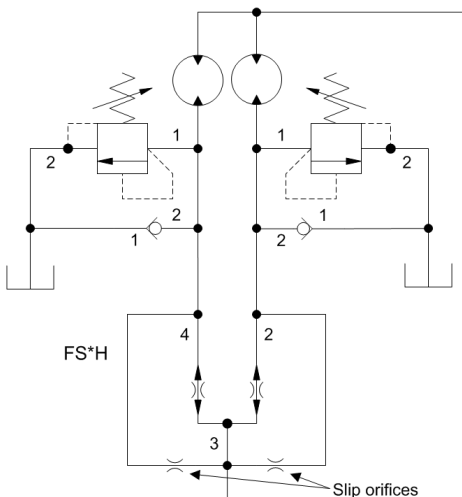

Use FS\*H flow divider/combiner cartridges, plus external slip orifices, in hydraulic motor tractive drive circuits. (Sun YG\*B manifold assemblies include selectable slip orifices.) Motor port relief valves and anti-cavitation check valves should also be included in the final circuitry.

Figure 5.

**Synchronizing Flow Divider/Combiner Cartridges – FS\*S, FSCS, FSDS and FS\*R**

Sun standard accuracy FS\*S, plus high accuracy FSCS, FSDS, and FS\*R synchronizing flow divider/combiner cartridges allow synchronization of two hydraulic cylinders. After the first cylinder has reached the end of its' stroke, a pressure-compensated reduced flow is metered to/from the second cylinder until it also reaches the end of its' stroke. (See Figure 6) Optimized performance parameters include:

- Broad flow capacity relative to physical size.
- 50:50 flow split ratio only.
- Bi-directional static error correction.
- Standard accuracy divisional and combining tolerances range from +/- 2.5% of 50% at maximum rated input flow down to +/- 4.5% of 50% at minimum rated input flow, with 5000 psi (350 bar) differential between legs. High accuracy divisional and combining tolerances range from +/- 2.0% of 50% at maximum rated input flow down to +/- 3.5% of 50% at minimum rated input flow, with 5000 psi (350 bar) differential between legs.
- Synchronization flow is equal to approximately 15% of minimum rated flow.

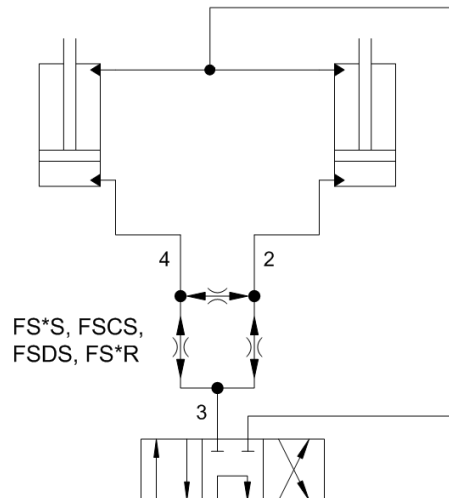

FS\*S, FSCS,  
FSDS, FS\*R

Figure 6.

Synchronizing flow divider/combiner cartridges will not only accurately split the flow to two cylinders in both directions, but will allow synchronizing at the end of stroke. However, **Cylinders must not be rigidly connected together!**

**Note:** When using flow controls in conjunction with flow dividers, care must be taken with the orientation and position of the flow controls. See Figure 7 for further details.

### How to Use Flow Controls with Flow Dividers

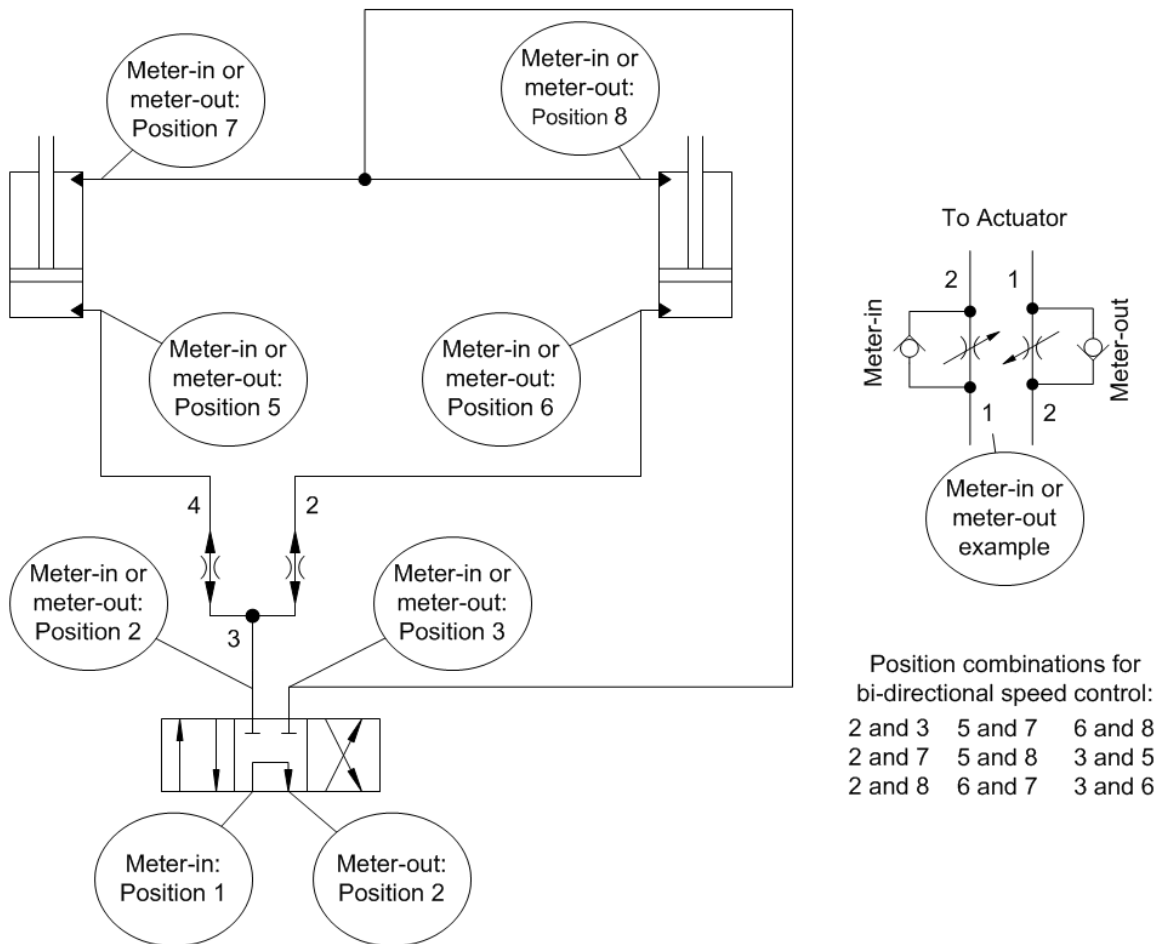

**Figure 7.**

Allowable Flow control positions for bi-directional control of cylinder speed. In all cases, both flow controls must be either meter-in or meter-out, and have reverse free flow capability.

**Flow Divider and Flow Divider/Combiner Valves Overview**

Function	Description	Nominal Capacity	Model	Cavity	Symbol
Divider	Divide Only	1.5 - 8 gpm (6 - 32 L/min.) 3 - 15 gpm (12 - 60 L/min.) 6 - 30 gpm (23 - 120 L/min.) 12 - 60 gpm (45 - 240 L/min.)	FSCD FSDD FSED FSFD	T-31A T-32A T-33A T-34A	
Divider	Divide Only— High Accuracy	0.6 - 3 gpm (2,5 - 12 L/min.) 1.5 - 8 gpm (6 - 32 L/min.) 3 - 15 gpm (12 - 60 L/min.) 6 - 30 gpm (23 - 120 L/min.)	FSBD FSDC FSEC FSFC	T-31A T-32A T-33A T-34A	
Divider/Combiner	Closed Center	1.5 - 8 gpm (6 - 32 L/min.) 3 - 15 gpm (12 - 60 L/min.) 6 - 30 gpm (23 - 120 L/min.) 12 - 60 gpm (45 - 240 L/min.)	FSCA FSDA FSEA FSFA	T-31A T-32A T-33A T-34A	
Divider/Combiner	Closed Center— High Accuracy	0.3 - 1.5 gpm (1 - 6 L/min.) 0.6 - 3 gpm (2,5 - 12 L/min.) 1.5 - 8 gpm (6 - 32 L/min.) 3 - 15 gpm (12 - 60 L/min.) 6 - 30 gpm (23 - 120 L/min.)	FSAA FSBA FSDG FSEG FSFG	T-31A T-31A T-32A T-33A T-34A	
Divider/Combiner	Closed Center— High Capacity	2 - 10 gpm (8 - 40 L/min.) 4 - 20 gpm (15 - 80 L/min.) 8 - 40 gpm (32 - 160 L/min.) 15 - 80 gpm (60 - 320 L/min.)	FSCH FSDH FSEH FSFH	T-31A T-32A T-33A T-34A	
Divider/Combiner	Synchronizing	1.5 - 8 gpm (6 - 32 L/min.) 3 - 15 gpm (12 - 60 L/min.) 6 - 30 gpm (23 - 120 L/min.) 12 - 60 gpm (45 - 240 L/min.)	FSCS FSDS FSES FSFS	T-31A T-32A T-33A T-34A	
Divider/Combiner	Synchronizing— High Accuracy	0.3 - 1.5 gpm (1 - 6 L/min.) 0.6 - 3 gpm (2,5 - 12 L/min.) 1.5 - 8 gpm (6 - 32 L/min.) 3 - 15 gpm (12 - 60 L/min.) 6 - 30 gpm (23 - 120 L/min.)	FSAS FSBS FSDR FSER FSFR	T-31A T-31A T-32A T-33A T-34A	